



SLIDING DOORS

SF60 & SF80

ULTRA ENERGY-EFFICIENT
GERMAN DESIGNED DOOR SYSTEMS



Schiebefenster SF60 / SF80 // Sliding Doors SF60 / SF80

Die SUNFLEX Schiebefenster SF60 und SF80 vereinen filigrane Profilbreiten mit maximaler Transparenz. Sie schaffen einen fließenden Übergang zwischen Innen- und Außenbereichen und bieten so eine beeindruckende Ansicht. Dabei erfüllen sie höchste Qualitäts- und Sicherheitsstandards und setzen Maßstäbe beim Komfort. Die Schiebeflügel der SF60 und SF80 überzeugen durch einen besonders leichtgängigen Lauf und erfüllen, in wärmedämmter oder hochgedämmter Ausführung, gehobene Dichtigkeitsanforderungen.

The SUNFLEX SF60 and SF80 sliding doors combine slim profile widths with maximum transparency. They create a smooth transition between indoor and outdoor areas, offering an impressive view. They also fulfil the highest standards for quality and safety, and set new benchmarks for convenience. The sliding leaves of the SF60 and SF80 impress thanks to their smooth-running design, and fulfil high sealing requirements in the thermally insulated or highly insulated design.

Handhabung // Handling

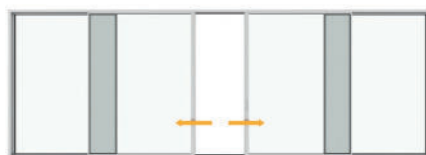

Entriegeln und Schieben des Öffnungsflügels
Unlocking and sliding the opening panel



Leichtes Verschieben der Elemente durch integrierte Mitnehmer
Easy displacement of the elements by integrated followers



Großer Öffnungsbereich bei geöffneten Elementen
Large open area when elements are opened

Systeminformationen // System information

- SF60 wärmedämmtes Aluminiumsystem
- SF80 hochwärmedämmtes Aluminiumsystem
- Nach Wunsch links und/oder rechts öffnend
- Öffnungsarten: 2- oder 3-spurig
- Stahlverstärkung bei hohen Windlasten im Mittelstoß möglich
- Bautiefe: 2-spurig 170 mm, 3-spurig 260 mm (SF60)
- Bautiefe: 2-spurig 210 mm, 3-spurig 320 mm (SF80)
- Glasstärke 32 bis 34 mm (SF60)
- Glasstärke 52 bis 54 mm (SF80)
- Kugelgelagerte Edelstahlaufrollen und Edelstahlaufschienen
- Max. Flügelgewicht: 800 kg
- Uw ab 0,8 W/m²K je nach Größe und Verglasung
- Luftdurchlässigkeit geprüft nach DIN EN 1027:2016-09/ DIN EN 12208-2000-06 Klasse 4 (SF60), Klasse 4 (SF80)*
- Schlagregendichtigkeit geprüft nach DIN EN 1027:2016-09/ DIN EN 12208-2000-06 Klasse 9A (SF60), Klasse E750 (SF80)*
- Windlast geprüft nach DIN EN 1027:2016-09/ DIN EN 12208-2000-06 Klasse C3/B5 (SF60), Klasse C5 (SF80)*
- Einbruchschutz bis Widerstandsklasse RC2

Schmale Ansichtsbreiten:

- Außenrahmen 60 mm, vollständig abdeckbar
- Bodenschiene 80 mm, vollständig einlassbar
- Flügelrahmen 45 mm, davon 21 mm sichtbar
- Mittelstoß 30 mm

- SF60 thermally insulated aluminium system
- SF80 highly insulated aluminium system
- Sliding to the left or right as desired
- Opening types: 2- or 3-track
- Steel reinforcement possible in the middle joint for high wind loads
- Construction depth: 2-track 170 mm, 3-track 260 mm (SF60)
- Construction depth: 2-track 210 mm, 3-track 320 mm (SF80)
- Glazing thickness 32 up to 34 mm (SF60)
- Glazing thickness 52 up to 54 mm (SF80)
- Ball-bearing stainless steel rollers and stainless steel rails
- Max. casement weight: 800 kg
- Uw from 0.8 W/m²K depending on size and glazing
- Air permeability certificated DIN EN 1027:2016-09/ DIN EN 12208-2000-06 Class 4 (SF60), Class 4 (SF80)*
- Driving rain resistance certificated DIN EN 1027:2016-09/ DIN EN 12208-2000-06 Class 9A (SF60), Class E750 (SF80)*
- Wind load certificated DIN EN 1027:2016-09/ DIN EN 12208-2000-06 Class C3/B5 (SF60), Class C5 (SF80)*
- Burglar resistance up to resistance class RC2

Narrow face widths:

- Outer frame 60 mm, completely coverable
- Floor track 80 mm, fully recessed
- Panel frame 45 mm, 21 mm of which is visible
- Center joint 30 mm

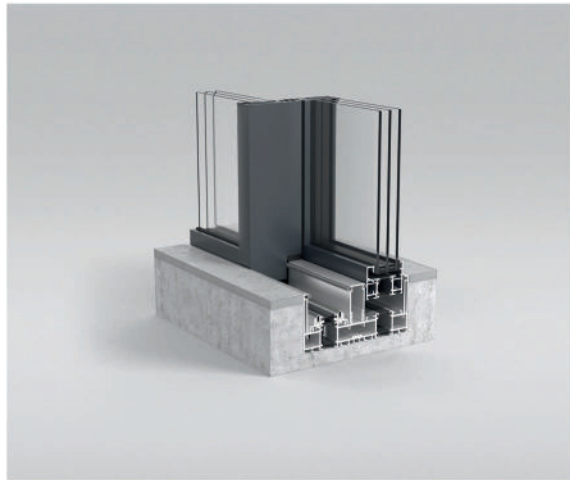

Profil

- Wärmegedämmtes Aluminium-Schiebefenster (SF60)
- Hochwärmegedämmtes Aluminium-Schiebefenster (SF80)

Profil

- thermally insulated aluminium sliding door (SF60)
- highly insulated aluminium sliding door (SF80)

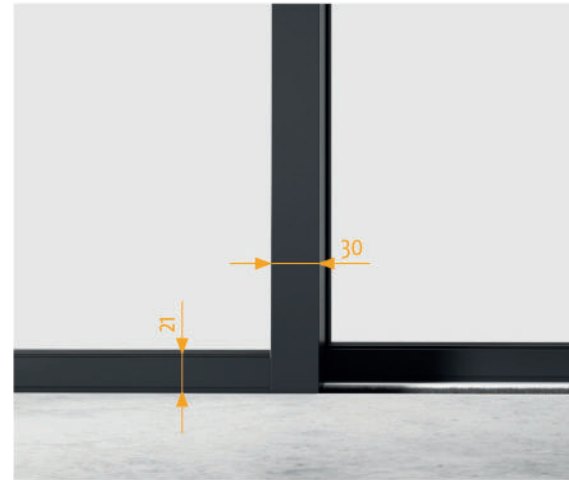

Design

- Geringe Ansichtsbreiten aller Profile sorgen für eine homogene Optik

Design

- narrow visible widths of all profiles create a homogeneous look



Verriegelung

- Pilzkopfverriegelung für optimale Dichtigkeit und erhöhte Einbruchsicherheit

Locking

- mushroom head lock for optimal seal and improved burglary resistance



Griffe

- flache kubische Form, ohne Profilzylinder

Handles

- flat, cube shape, without profile cylinder

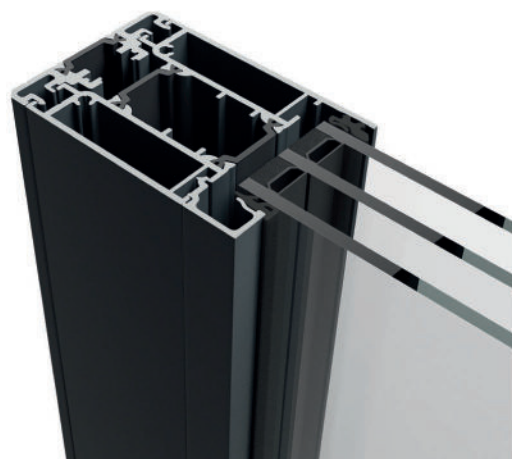

Glasleisten

- einfache Ausrichtung und Verglasung der Gläser durch umlaufende Glasleisten möglich

Glazing beads

- easy alignment and glazing of glass panes thanks to glass strips on all sides



Feinjustierung

- Montageschuhe ermöglichen eine schnelle Montage sowie die Feinjustierung der senkrechten Rahmenprofile

Fine adjustment

- mounting levers ensure quick installation and fine adjustment of the vertical frame profiles



Griffe

- flache kubische Form, mit Profilzylinder

Handles

- flat, cube shape, with profile cylinder



Griffe

- Muschelgriff (außen)

Handles

- recessed mould (outside)



Decken- und Bodenschiene //
Ceiling and bottom rail

Flügelteilung //
Panel division

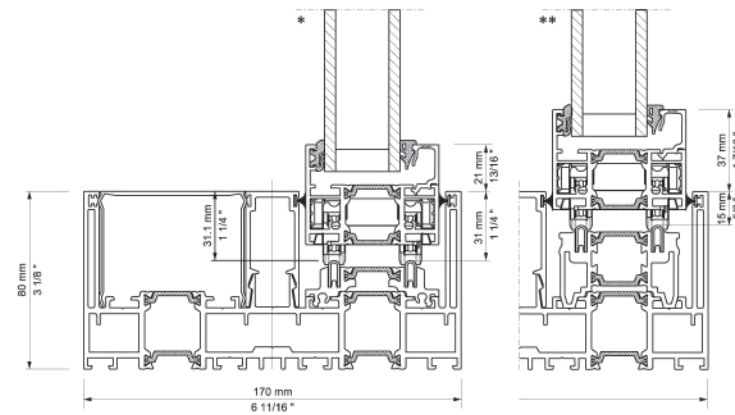
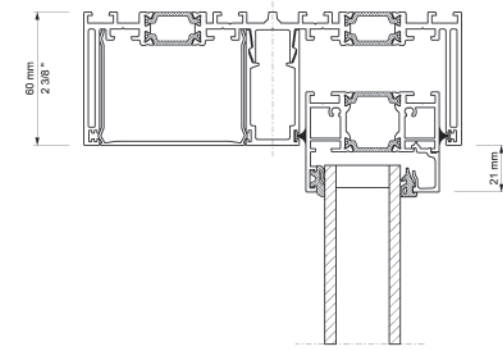

- * Standardausführung
- ** Barrierefreie Ausführung nach DIN 18024
- * Standard version
- ** Barrier-free design according to DIN 18024

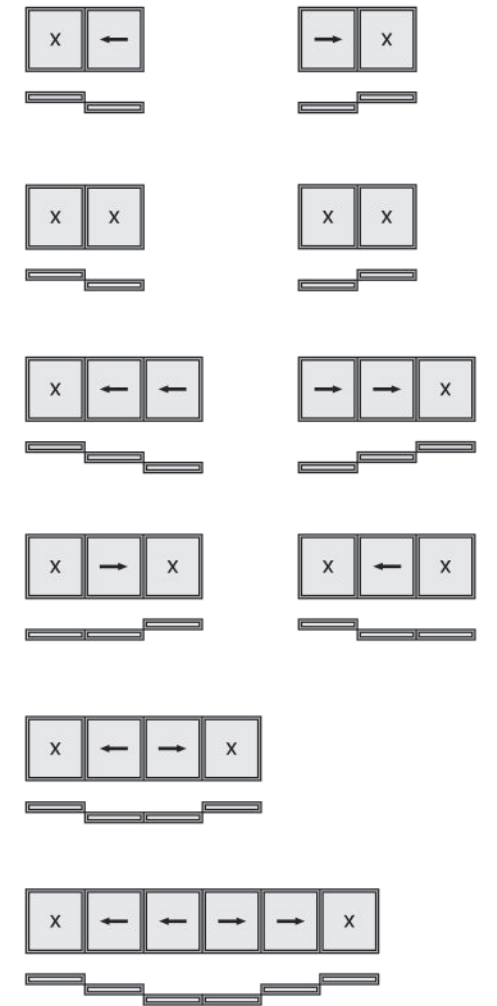

Seitlicher Wandanschluss //
Lateral wall connection

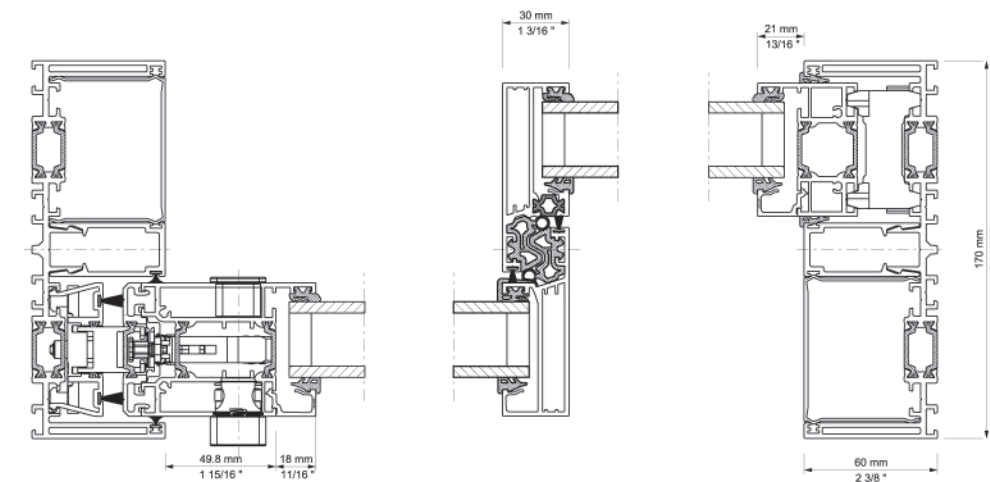



sliding doors



bifold doors



slide & turn doors



heritage doors



aluminium windows



glass roofs



internal glazing



front doors



glass balustrades

IDSystems
innovative glazing

t 01603 408804 e info@idsystems.co.uk

B2 Rhombus Park Diamond Road Norwich NR6 6NN

www.idsystems.co.uk/sliding-doors

See the **SF60 & SF80** at
▶ **Our Comprehensive Showroom** in Norwich

