



TIMBER CLAD

# BIFOLD DOORS

ALUMINIUM DOORS WITH  
INTERNAL TIMBER

# SUNFLEX™ Composite bifold doors

These highly engineered timber clad aluminium bifold doors, designed and manufactured for us in Germany by SUNFLEX, offer the ideal combination of a hardwearing aluminium exterior frame and the natural beauty of timber on the interior face of the door. Available double or triple glazed with a choice of timbers, cladding styles and finishes (along with more than 200 different paint colours for the aluminium and wood) the SUNFLEX SF55c and SF75c are perfect for traditional properties or for adding character to new builds or extensions.



Secured by Design



Official Police Security Initiative

For over thirty years, SUNFLEX has led the global market in the design, development and manufacture of bifold doors. Today they are widely regarded as the most advanced systems available, with each product handmade to the highest quality and featuring a wide range of unique features and system options.

The advanced engineering of the SUNFLEX SF55c and SF75c doors means they offer the greatest protection from wind and rain whilst closed, whilst the patented polyamide thermal break technology makes the doors amongst the most thermally efficient composite doors available.

Unlike other composite doors on the market where timber doors are clad with aluminium the SUNFLEX composite door systems are not susceptible to warping, twisting or rotting because the structure of the doors is aluminium with just a small section of timber cladding attached to the inner face of the door.

For more than 20 years IDSystems has been the largest installer of SUNFLEX systems in the UK and we now install more SUNFLEX bifold doors each year than anyone else in the world.

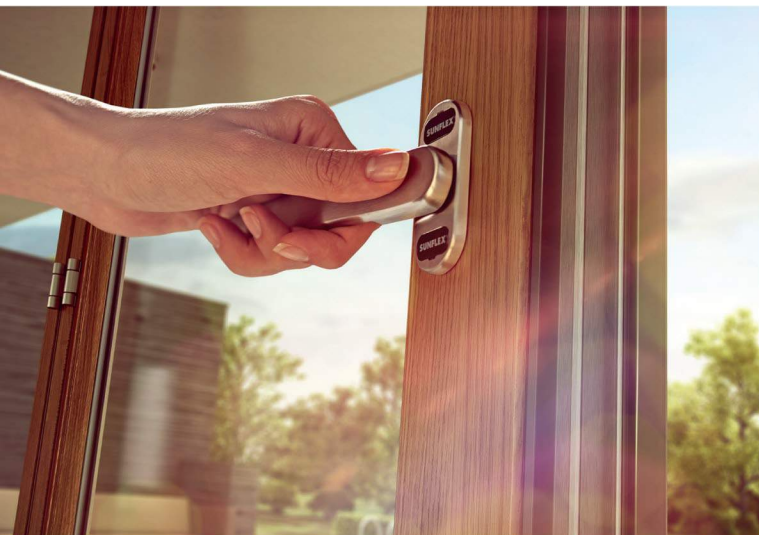

5-panel SF55c | RAL 9007 external, moulded American White Oak internal | 5-left | weathered track



5-panel SF75c | RAL 9006 external, Nordic Pine internal | 5-left | weathered track

# SUNFLEX SF55c

Thermally insulated composite bifold doors – available with double or triple glazing

The SUNFLEX SF55c bifold door represents the very best of both worlds with a thermally broken aluminium frame on the outside to match your windows and timber cladding on the inside to match the look of your room.

The system shares all the same performance and aesthetic characteristics of the award-winning SUNFLEX SF55 aluminium system.

Flexibility in design – the system may be opened to the inside or out, folded to the left or the right (or both). It can have panels all folding the same way or split with a number folding to each side. The system can be double or triple glazed, utilised as a single door, French doors and from 2-panel to 22-panel bifold door on three different track options. It can also include a moveable corner post to create an eye-catching complete opening.

## SF55c Track options

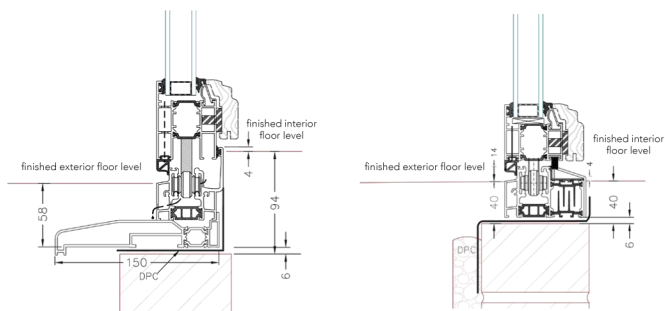

Weathered track on sill

Low threshold track with no sill

## SF55c U-Values

Glazing option	Overall system U-value
Double glazed	from 1.4 W/m <sup>2</sup> K
Triple glazed	n/a

## SF55c KEY FEATURES

- The most weathertight bifold doors available  
Independently tested to 900Pa water tightness (Class 9A), 600Pa air permeability (Class 4) and 1,600Pa wind load (Class A4).
- Narrow sight lines  
118mm – maximising light and enhancing your view.
- Slim front to back profile  
70mm – minimising stacking area.
- Extremely versatile  
Up to 1,200mm wide panels, 3,500mm high; open in or out; flush, low or weathered track option.
- Patented thermal break  
Advanced 24mm shaped polyamide thermal break.
- Secured by Design™  
Designed, manufactured and installed to Police preferred specification.
- PAS 24:2016  
The doors meet and exceed the requirements of Part Q of Building Regulations.
- Advanced finger safe gasket  
Continuous interlocking triple EPDM gasket, front and back, for finger cushioning and tight compression seals.
- Panel catch  
Unique panel catch holds first door in place during opening.
- Stacking clip  
Innovative stacking clip secures system when doors are fully opened.
- Corner openings  
Can be achieved with integration of moveable corner post.
- Mushroom locking  
Locking into the side jamb, coupled with top and bottom metal shoot bolt rods, gives excellent security. WK2 security package available.



6-panel SF55c | Silver anodised external, Nordic Pine internal | 3-left, 3-right | low threshold track



5-panel SF55c | RAL 7031 external, American White Oak internal | 5-left | weathered track



6-panel SF55c | Silver anodised external, Nordic Pine internal | 3-left, 3-right | low threshold track



3-panel SF55c | RAL 9007 external, Meranti internal | 3-left | flush track

# SUNFLEX SF75c

The most thermally efficient timber clad aluminium composite bifold door on the market

Based on the market leading SUNFLEX SF75 system, the SF75c has been specifically developed to offer the most thermally advanced composite bifold door of its type available, with a U-value as low as 0.8W/m²K when triple glazed. Combined with the industry leading weather performance this helps reduce energy consumption and contributes to savings on heating bills.

Designed for performance - the SF75c is a unique composite bifold door system, specifically designed to accommodate a triple glazed sealed unit. This design, along with the precision German engineering and superior attention to detail enables the system to perform to the highest levels of thermal efficiency, as well as maintaining the stunning visual appearance, slim sight lines and configuration options. The SF75c is available with a choice of two track options, a weathered track for ultimate protection from the elements and a low-threshold track that is DDA compliant.

## SF75c Track options

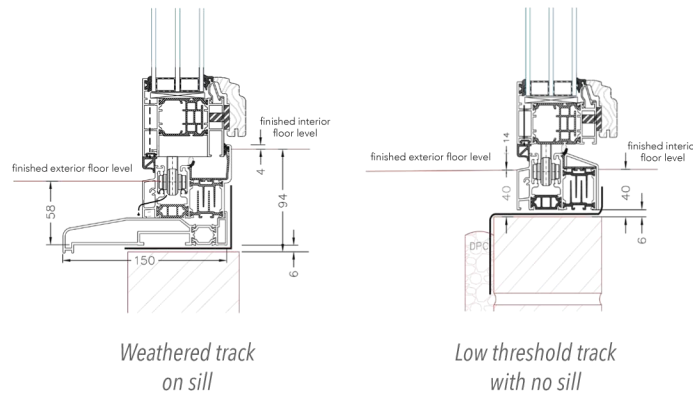

## SF75c U-Values

Glazing option	Overall system U-value
Double glazed	n/a
Triple glazed	from 0.8 W/m²K

## SF75c KEY FEATURES

- The most thermally efficient timber clad aluminium composite bifold doors  
Overall U-values of as low as just 0.8W/m²K.
- Patented thermal break  
Advanced multi-chamber 44mm polyamide thermal break.
- Narrow sight lines  
118mm - maximising light and enhancing your view.
- The most weathertight bifold doors available  
Independently tested to 900Pa water tightness (Class 9A), 600Pa air permeability (Class 4) and 1,600Pa wind load (Class A4).
- Severe weather rating  
With weathered track, providing industry leading protection from wind and rain, with test results of 900Pa water tightness and 600Pa air permeability.
- Large panels sizes possible  
Each panel can be up to 1,200mm wide panels and 3,500mm high.
- Track options  
Choose from the high performance weathered track or DDA compliant low threshold track option.
- Advanced finger safe gasket  
Continuous interlocking triple EPDM gasket, front and back, for finger cushioning and tight compression seals.
- Panel catch  
Unique panel catch holds first door in place during opening.
- Stacking clip  
Innovative stacking clip secures system when doors are fully opened.
- Secured by Design™  
Designed and installed to Police preferred specification.
- PAS 24:2016  
The doors meet and exceed the requirements of Part Q of Building Regulations.
- Mushroom locking  
Locking into the side jamb, coupled with top and bottom metal shoot bolt rods, gives excellent security. WK2 security package available.
- Corner openings  
Can be achieved with integration of moveable corner post.



4-panel SF75c | RAL 7012 external, American White Oak internal | 1-left, 3-right | flush track



4-panel SF75c | RAL 9011 external, Douglas Fir internal | 1-right, 3 left | flush track



4-panel SF75c | RAL 7012 external, American White Oak internal | 1-left, 3-right | flush track

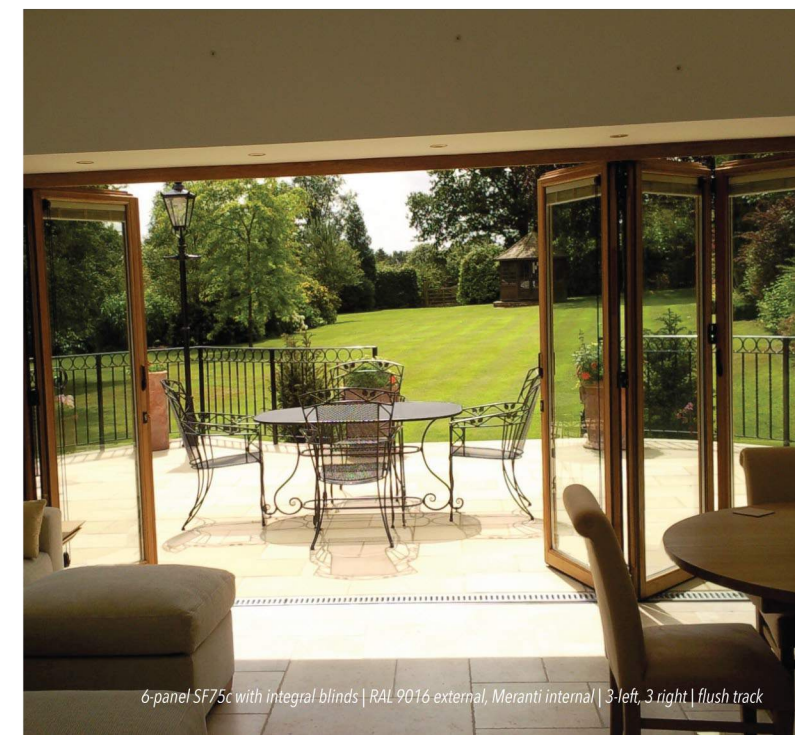

6-panel SF75c with integral blinds | RAL 9016 external, Meranti internal | 3-left, 3 right | flush track

## Aluminium finishes

We have chosen 5 of our most popular finishes as standard colours for the outer aluminium frame of your doors, these are White RAL 9016 semi-gloss, Aluminium RAL 9006 semi-gloss, Grey Aluminium RAL 9007 semi-gloss, Anthracite Grey RAL 7016 semi-gloss and Silver anodised.

Alternatively you can choose from more than 200 RAL colours for the outer frame while handles and hinges can also be colour coded to match your choice of door colour as well as the ever popular choice of stainless steel door furniture.



## Timber cladding options

The SUNFLEX SF55c and SF75c doors are available in two standard timber cladding options, Meranti - a durable hardwood or Nordic Pine - a knot-free softwood. You can also select from a non-standard timber option including American White Oak, Larch or Douglas Fir.



Meranti

Nordic Pine

American White Oak

Larch

Douglas Fir



## Timber cladding styles

Choose from three timber cladding styles to give the interior of the doors the look that best matches your project. The moulded profile provides more intricate, traditional detail to the cladding, the plain profile gives a nicely curved finish or the squared profile provides a clean contemporary design.

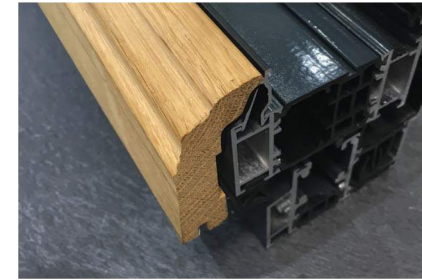

Moulded

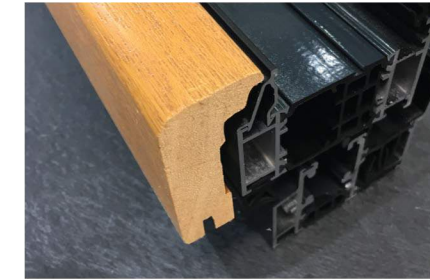

Plain

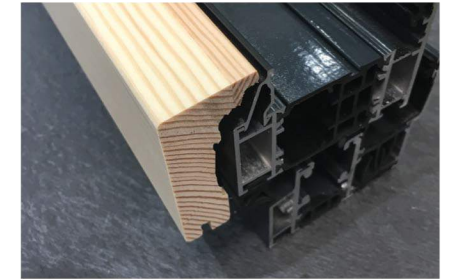

Squared

## Timber finishes

Once you've decided upon your choice of timber you then have a wide range of stains, finishes or even paint options to completely personalise your doors. Choose from a wide range of Sikken's™ wood stains, with the choice of having different stains or even paint finishes available for interior and exterior surfaces also available. Illustrated below are our range of standard stain finishes.

### Finishes on Meranti



Ash

Pine

Old pine

Light oak

Dark oak

Teak

Mahogany

Rosewood

Walnut

Ebony

#### PLEASE NOTE:

Whilst every effort has been made to display the timber choices and stain options accurately the images shown should be used as an indication only. We can supply samples of various timbers and/or timber finishes if required, simply email us at [info@idsystems.co.uk](mailto:info@idsystems.co.uk) or call 01603 408804.

### Finishes on Nordic Pine

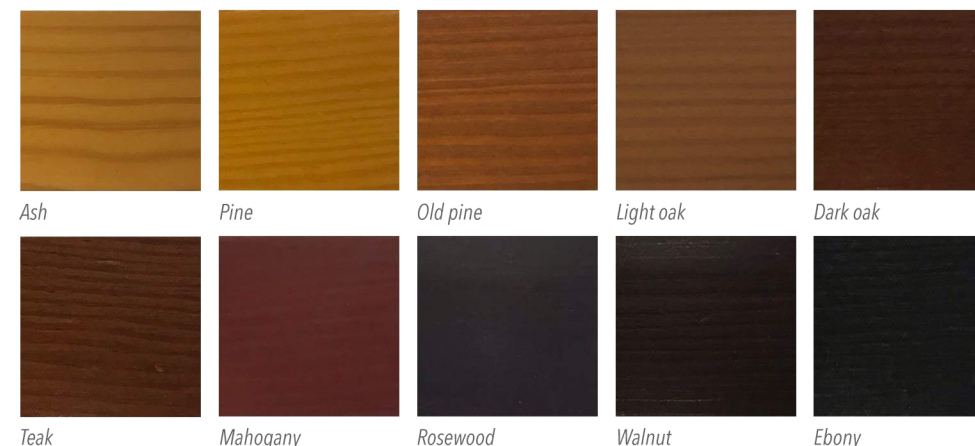

Ash

Pine

Old pine

Light oak

Dark oak

Teak

Mahogany

Rosewood

Walnut

Ebony

Clear (internal use only)



## Unique range of features



Finger safe gaskets

Industry-leading weather protection

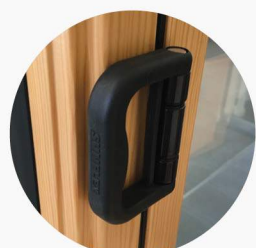

Pull Handle

Track options

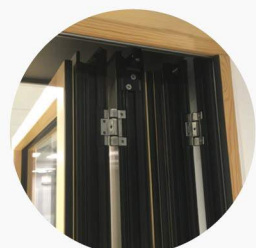
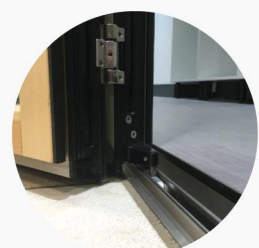

Exclusive stacking clip technology

Patented antiSLAM panel catch



Unique in-line handle design

Integrated Venetian blind



3-panel theEDGE2.0 | RAL 7016 Anthracite grey | 3-right | double track

## Complete glazing solutions, whatever your project...

Award-winning bifold doors, sliding doors and glazing solutions - all made to fit your home perfectly.

Transforming your home needs an experienced and safe pair of hands, so choosing the right company to work with is important. At IDSystems, we're the market leader in providing multi-award winning glazing solutions for all types of projects - extensions, renovations, self-build projects and complete new builds. We guarantee the highest standards of advice, build quality, design and bespoke installation for your complete peace of mind. As a family business founded in 2000, we've built an outstanding reputation for quality, service, expertise and some of the most exciting and innovative designs. From your very first contact with us, you'll know that you're dealing with an industry leader. From our initial designs and technical advice to liaison with architects and builders, creating working CAD drawings and the logistics of final installation, our own staff will be with you every step of the way.





sliding doors



bifold doors



slide & turn doors



heritage doors



aluminium windows



glass roofs



internal glazing



front doors



glass balustrades

  
**IDSystems**  
innovative glazing

t. 01603 408804 e. info@idsystems.co.uk

B2 Rhombus Park, Diamond Road, Norwich, NR6 6NN

[www.idsystems.co.uk/bifold-doors](http://www.idsystems.co.uk/bifold-doors)

See our **bifold doors** at

- ▶ The Building Centre in Central London
- ▶ Our Comprehensive Showroom in Norwich

